





TABLE OF CONTENTS

GENERAL	4
Introduction	4
Spare parts and adaptations	4
Tightening Allen screws	4
Torque	5
Checks	5
Identifying and alleviating malfunctions	5
FRAME	6
SEAT	7
Seat width (SB)	7
Seat depth (ST)	7
Front seat height (SHv)	7
Rear seat height (SHh)	9
Seat angle (SW)	9
Tipping point adjustment	10
Suspension	10
BACKREST	11
Backrest height (RH)	12
Adjusting the backrest height	12
Securing/adjusting the release cord	12
Replacing the backrest tube	13
Replacing the handle	14
Replacing foldable push handles	14
Backrest angle (RW)	15
FOOTRESTS	16
Lower leg length (UL)	16
Replacing footrests	16
Adjusting the footrest height	16
Fitting and adjusting high-mounted footrest	17
Angle-adjustable footplate, adjusting the angle	17
Fit fold-up footrest	17
SIDE PARTS	18
Armrest	18
Clothes-guard/mudguard	19
FRONT WHEELS	21
Replacing a front wheel	21
Replacing a front wheel fork	21
REAR WHEELS	22
Ensuring the rear wheels are parallel	22
Adjusting the removable axle	22
Fitting and adjusting a rear wheel extension	22
Changing the wheel chamber / Fitting and adjusting an axle	23
BRAKES	24
Fitting / adjusting the parking brake	24
OPTIONS & ACCESSORIES	25
Antitipper	25
Active antitipper	26
Transit wheels	26
Fitting the pelvic belt	27
Attaching the snap hook symbols	27

GENERAL

Introduction

This service manual is part of the instructions and contains the technical information for servicing, configuring and repairing a küschall® wheelchair.



WARNING!

Danger of accident and severe injuries.

If the wheelchair is improperly set it can cause accidents and severe injuries.

► **Changes to the wheelchair may only be carried out by the provider.**

To guarantee the required safety and reliability, all wheelchairs must be comprehensively checked once a year.

In part, assembly and adjustment require extensive experience. For this reason, the following assembly instructions have been split into three categories:

Requirement	Symbol
Easy – technical understanding required	●○○
Intermediate – specialist knowledge required	●●○
Difficult – specialist wheelchair assembly knowledge and experience required	●●●

The required tools and their respective sizes are listed above each instruction. The instructions include information on the torques with which the respective screw connections must be tightened. Adhering to the given torques requires the use of a torque spanner.

Tools	Symbol
Allen key	◆ 3, 4, 5
Phillips screwdriver	✕ 2
Straddle spanner	—C 10, 11, 19
Socket spanner/ring spanner	◻ 8, 10

Spare parts and adaptations

All spare parts can be purchased from Küschall®'s Customer Services. An electronic spare parts catalog is available by logging onto www.kuschall.com. Only original spare parts may be used. Installing additional adaptations to a küschall® wheelchair requires the prior written approval of Küschall AG.

Tightening Allen screws

Allen keys are not designed for greater forces. When tightening or loosening an Allen screw, it is therefore advisable to apply force to the nut to prevent the hexagon socket from being damaged.

Tightening and loosening

- Turn the nut with a socket spanner (only use a straddle spanner if there is insufficient space) and merely hold the screw tight with the Allen key.

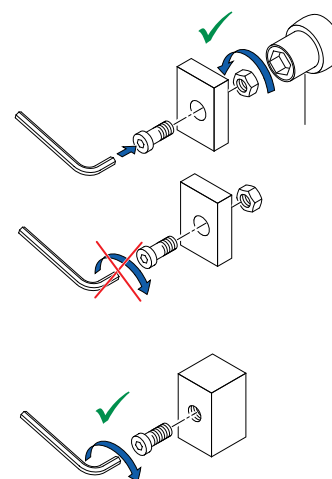
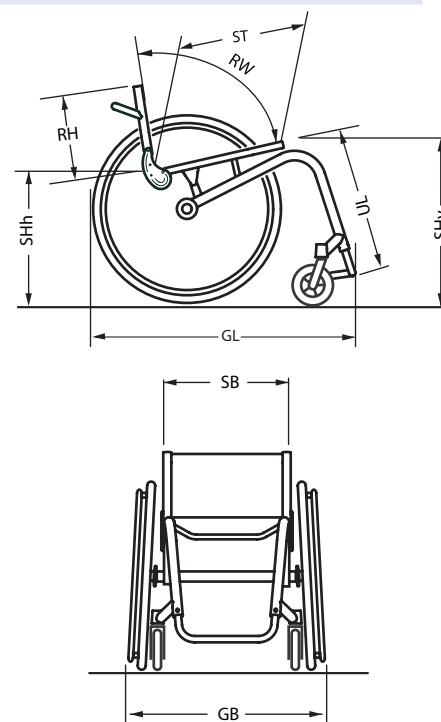



Tightening and loosening if there is no nut

If an Allen screw is directly screwed into a screw thread, the screw must be tightened using an Allen key.

-  Ensure that the Allen key is of good quality and not worn.

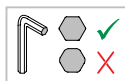

Torque

- All screw connections must be tightened with the torques specified in the following instructions.

Checks

Visual check

- Check all components for cracks, especially the areas around joints and welded seams.

Checking the screw connections

- Check all bolts with the torques specified in the instructions regularly, and adjust if required.



CAUTION!

Several screw connections have been secured with thread locking adhesive. If these are opened, they must be secured again using new thread locking adhesive.

Liquid high-strength and low-strength adhesives are available. For torque entries notice shall be made whether an adhesive and which adhesive needs to be used.

Identifying and alleviating malfunctions

Malfunction	Possible cause	Measure
The wheelchair will not move in a straight line	Incorrect tire pressure in a rear wheel	Correct tire pressure
	One or more spokes broken	Replace defective spoke(s)
	Spoke unevenly tensioned	Tighten excessively loose spokes
	Dirty or damaged wheel bearings	Clean or replace bearings
The wheelchair tips backwards too easily	Rear wheels have been fitted too far forward	Fit rear wheels further back
	Backrest angle too great	Reduce backrest angle
	Seat angle too great	Use longer vertical struts
The brakes engage poorly or asymmetrically	Incorrect tire pressure in one or both rear wheels	Correct tire pressure
	Brake setting incorrect	Correct brake setting
Roll resistance is too great	Insufficient tire pressure in the rear wheels	Correct tire pressure
	Rear wheels are not parallel	Ensure that the rear wheels are parallel
The front wheels wobble when moving fast	Insufficient tension in the front wheel bearings block	Lightly tighten the nut in the bearings block axle
	Front wheel is worn flat	Replace front wheel
The front wheel is stiff or stuck	Dirty or damaged bearings	Clean or replace the bearings
Increased forward tip tendency	Frame deformed	Replace frame



FRAME

The K-Series frame is available in aluminium, titanium and carbon. Aluminium and titanium frames come with frame angles of 75° and 90°; carbon frames come with a frame angle of 75°. Furthermore, the 75° and the 90° aluminium frames come with adduction and in a short, respective +5 version.

Frame		Front seat height (SHv) in mm (with a 24" rear wheel)*	Lower leg length (UL) with standard-mounted bar	Lower leg length (UL) with standard-mounted fold-up footrest	Seat depth (ST)
Aluminium	75° short	450 to 470	SHv -120** to SHv -30	SHv -160** to SHv -30	375 to 450
	75° standard	480 to 500	SHv -110** to SHv -30	SHv -150** to SHv -30	375 to 450
	75°+5	500 to 520	SHv -110** to SHv -30	SHv -150** to SHv -30	425 to 525
	90° short	450 to 470	SHv -140** to SHv -40	SHv -180** to SHv -40	375 to 450
	90° standard	480 to 500	SHv -130** to SHv -40	SHv -170** to SHv -40	375 to 450
	90°+5	500 to 520	SHv -130** to SHv -40	SHv -170** to SHv -40	425 to 525
	75° adduction	480 to 500	SHv -110** to SHv -30	SHv -150** to SHv -30	375 to 450
	90° adduction	480 to 500	SHv -130** to SHv -40	SHv -170** to SHv -40	375 to 450
Titanium	75° standard	480 to 500	SHv -110** to SHv -30	SHv -150** to SHv -30	375 to 450
	90° standard	480 to 500	SHv -130** to SHv -40	SHv -170** to SHv -40	375 to 450
Carbon	75° standard	490 to 500	SHv -110** to SHv -30	SHv -150** to SHv -30	375 to 450

*With a 25" rear wheel, the SHv is 10 mm greater in each case. With a 26" rear wheel, the SHv is 20 mm greater in each case.

**With a 25" rear wheel, deduct 10 mm in each case when calculating the lower leg length. With a 26" rear wheel, deduct 20 mm in each case from the SHv (see examples in the following Table).

Examples:

Frame	SHv in mm	Lower leg length (UL) with standard-mounted bar	Lower leg length with standard-mounted fold-up footrest
75° short, 25" rear wheel	460 to 480	SHv -130 to SHv -30	SHv -170 to SHv -30
75° short, 26" rear wheel	470 to 480	SHv -140 to SHv -30	SHv -180 to SHv -30

For **lower leg lengths**, the high-mounted footrest must be used. → Chapter: Footrests, <Assembling and adjusting high-mounted footrests>



SEAT

Seat width (SB)

Available seat widths: SB 340 to 480 in 20 mm steps.

Changing the seat width is very complicated and requires the replacement of numerous parts.

Seat depth (ST)

Available seat depths: ST 375 to 525 in 25 mm steps.

Changing the seat depth requires the replacement of the complete seat module including the seat cover and the seat rail and potentially also the seat cushion.

Front seat height (SHv)

The front seat height is dependent on several factors that interact with each other. The size of the rear wheels determines the height of the sub-structure. In addition to the size and the positioning of the brackets on the seat module, the frame, seat depth and rear seat height influence the seat height.

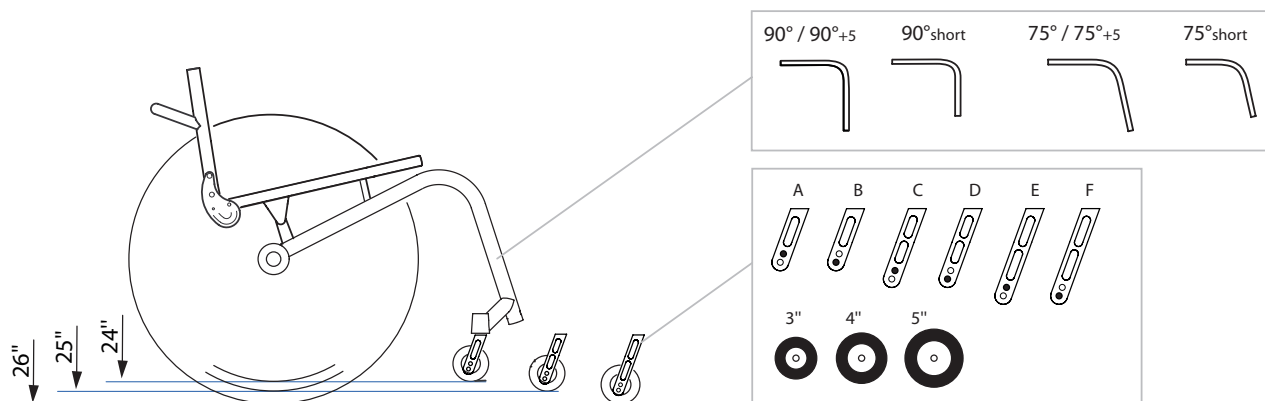



Possible front and rear wheel combinations				
Rear wheel	Frame	●3"	●4"	●5"
24"	75° short	F	E	D
	75° / 75°+5 / 90°short	D	C	B
	90° / 90°+5	B	A	--
25"	75° short	--	F	E
	75° / 75° +5 / 90°short	E	D	C
	90° / 90°+5	C	B	--
26"	75° / 75° +5	F	E	D
	90° / 90°+5	D	C	B

 Only select combinations listed in the Table to ensure that the frame is straight and the front wheel supports are perpendicular to the ground.

If the rear wheel, front wheel and front wheel fork are defined, the front seat height can be adjusted by changing the position of the seat module within the frame. There are 2 brackets available, each with 2 fixing options.

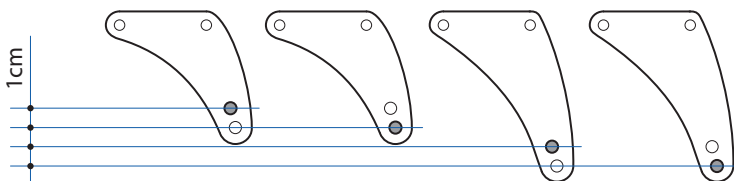

Positioning or replacing the brackets at the front for setting the front seat height (SHv)

Difficulty: ●●●

Tools: ● 4, 5

- Remove the rear wheels, fold the backrest forward and place the wheelchair on its back.
- Loosen the screws ① and ② that connect the seat brace ③ to the seat module or the frame on both sides.
- Remove the screw ⑤ and place it in the bracket's ④ other hole.
If you require a new bracket, remove the screws ⑤ and ⑥, replace the bracket ④ and fix it using the screws ⑤ and ⑥.
- Refit the rear wheels, stand the wheelchair back up and check the position of the seat braces ③. They must be as perpendicular to the ground as possible.
- Tighten the screw connections ① and ② of the seat braces and ⑤ and ⑥ of the front brackets again.
- Carry out the same setting on both sides.

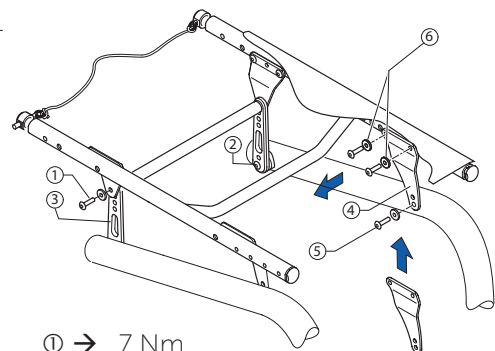

- ① → 7 Nm
- ② → 13 Nm
- ⑤ → 7 Nm
- ⑥ → 7 Nm

 Note: ensure that adjusting the front seat height results in a change to the seat angle. It may be necessary to correspondingly adjust the rear seat height (SHh) or the backrest angle.



Rear seat height (SHh)

The seat braces can be repositioned to adjust the rear seat height. The seat braces are available in three different sizes, covering seat heights of between 380 and 490 mm.

Generally, we recommend fixing the seat braces to the lower hole on the frame.

Rear seat height based on wheel position and wheel size									
SHh	24" wheel			25" wheel			26" wheel		
	S	M	L	S	M	L	S	M	L
380	1								
390	1		1						
400	2		1			1			
410	3	5a	2			1			
420	4	5	3	5a		2			
430	6	4	5			3	5a		
440	7	9a	6			4	5		
450	8	9	7	9a		6			
460		10	8	9		7	9a		
470		11		10		8	9		
480		12		11			10		
490				12			11		

Adjusting the rear seat height (SHh)

Difficulty: ●●●

Tools: ● 5

- Remove the rear wheels, fold the backrest forward and place the wheelchair on its back.
- Loosen the screw ① for the front bracket on both sides.
- If you can set the desired seat height using the existing seat brace ②, loosen the screw ③ and remove the screw ④ and the connecting bar ⑤.
- If you require a new seat brace, remove the existing one and the connecting bar ⑤ and loosely fix the new seat brace to the frame using screw ③.
- Slide the seat brace against the rear bracket so that the required holes overlap.
- Insert the connecting bar ⑤ and fix it with screw ④.
- Carry out the same setting on both sides.
- Refit the rear wheels, stand the wheelchair back up and check the position of the seat brace ③. It must be as perpendicular to the ground as possible.
- Tighten the screws ①, ③ and ④.

Note: ensure that adjusting the rear seat height results in a change to the seat angle. It may be necessary to correspondingly adjust the front seat height (SHv) or the backrest angle.

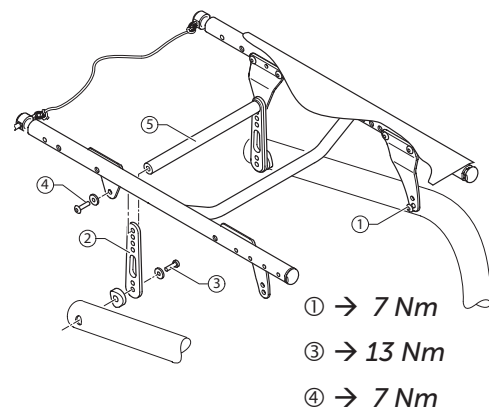

Seat angle (SW)

The seat angle is determined by the difference between the rear seat height (SHh) and the front seat height (SHv).



Tipping point adjustment

The tipping point of the wheelchair can be adjusted by changing the horizontal position of the seat module.

Difficulty: ●●●

Tools: ● 4, 5

- Remove the rear wheels, fold the backrest forward and place the wheelchair on its back.
- Loosen the screws ①, ② and ⑤.
- Remove the screws ③ and ④ and slide the seat module forwards or backwards.
- Fix the seat module with the screws ③ and ④ and tighten the screws ①, ② and ⑤ again.
- Carry out the same setting on both sides.

There are 3 possible positions for the rear bracket and 5 possible positions for the front bracket.

 Note: ensure that the seat brace ⑦ is as vertical as possible following an adjustment.

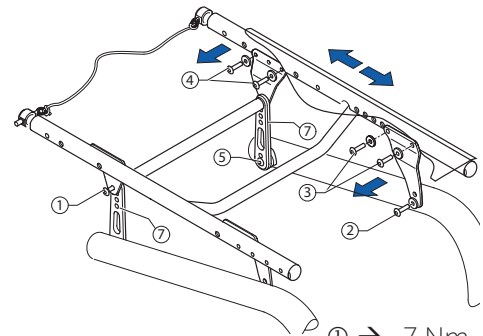

- ① → 7 Nm
- ② → 7 Nm
- ③ → 7 Nm
- ④ → 7 Nm
- ⑤ → 13 Nm

Suspension

A suspension can be fitted for a SHh of between 380 and 460.

Fitting a suspension

Difficulty: ●●●

Tools: ● 4, 5

- Remove the rear wheels, fold the backrest forward and place the wheelchair on its back.
- 1 Remove the seat module by removing the brackets at the front ① and the rear ②.
- Removing the seat brace ③.
- 2 Fit the suspension housing ④ to the frame. Here, slide the screw with the washer ⑤ through the suspension housing and place the lubricated sleeve with the spacer elements on the screw. Slide the screw ⑤ through the frame into the axle holder stay and tighten it firmly.

Function check:

It must be possible to rotate the suspension housing ④, but it must not be loose.

- 3 Insert the suspension seat strut ⑥ from above into the suspension housing ④. Slide the sleeve ⑦ from below over the suspension seat strut ⑥ and position it at the desired seat height. Fix it using the screw and the washer ⑧.
- Carry out the same setting on both sides.
- Lubricate the springs ⑨ and insert them into the suspension housing ④. Insert the screws ⑩ into the suspension housing until they protrude by 25 mm.
- 4 Fix the front and rear spring brackets to the seat module (screws ⑪), insert the lubricated rotating sleeves ⑫ and fix the seat module to the frame (screws ⑬) again.
- Reattach the wheels and stand the wheelchair up again.

Check:

Check the front seat height. When fitting the mudguard, ensure that it is at least 4 mm from the wheel. Check the suspension function.

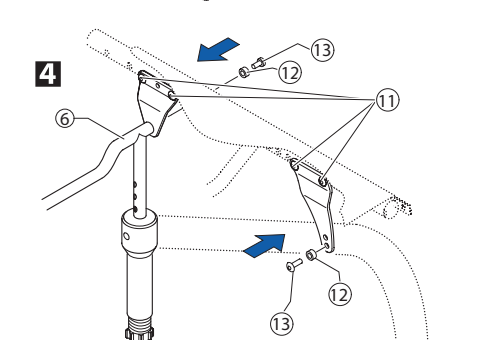
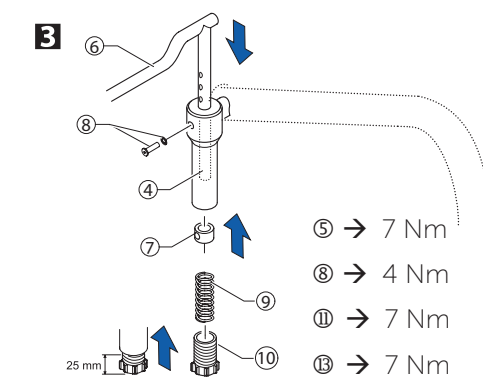
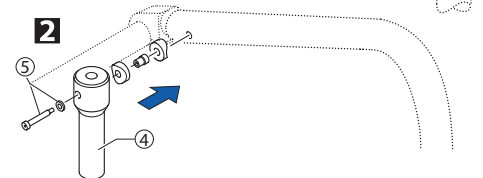
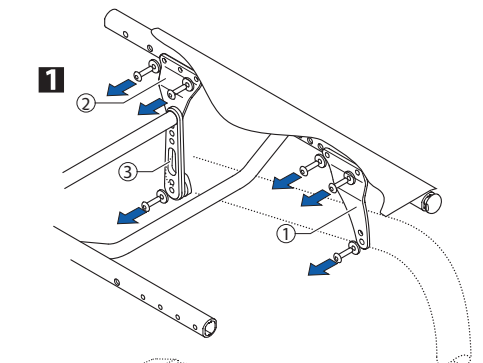



BACKREST

The adjustable back is fitted with velcro bands and a cover. Apart from the adjustable back there is the light cover, which is produced individually for each backrest height (RH) and seat width (SB).

Backrest height (RH) to cover, backrest tube, pushhandles and bands					
RH	cover	backrest tube ⑨	standard pushhandles ① foldable pushhandles ②		
			pushhandle ① telescopic tube straight ②	bands above stabilizing bar	top band
270*	S	S	S	1-band ⑦	backrest-band, 5 cm ⑤
285	S	S	S	1-band ⑦	
300	S	S	S	1-band ⑦	
315	S	L	S	1-band ⑦	
330	S	L	S	1-band ⑦	
345	M	L	S	2 x 1-band ⑦	
360	M	L	S	2 x 1-band ⑦	
375	M	L	S	2 x 1-band ⑦	
390	M	L	L	2-bands+1-band	
405	M	L	L	2-bands+1-band	
420	L	L	L	2-bands+1-band	
435	L	L	L	2-bands+1-band	
450	L	L	L	2 x 2-bands ⑧	
465	L	L	L	2 x 2-bands ⑧	
480	L	L	L	2 x 2-bands ⑧	

* RH 270 only for standard pushhandles

Backrest height (RH) to pushhandles, telescopic tubes and bands					
RH	without pushhandles ③		height adjustable pushhandles, rearsset ④		
	bands above stabilizing bar	top band	telescopic tube bended ③	bands above stabilizing bar	top band
270	1-band ⑦	end- band, 5 cm ⑥	-	-	endband, 5 cm ⑥
285	1-band ⑦		S	1-band ⑦	
300	1-band ⑦		S	1-band ⑦	
315	1-band ⑦	endband, 10 cm ⑥	S	1-band ⑦	endband, 10 cm ⑥
330	1-band ⑦		S	1-band ⑦	
345	1-band ⑦		S	1-band ⑦	
360	2 x 1-band ⑦		S	1-band ⑦	
375	2 x 1-band ⑦		M	1-band ⑦	
390	2 x 1-band ⑦		M	2 x 1-band ⑦	
405	2-bands+1-band		M	2 x 1-band ⑦	
420	2-bands+1-band		M	2 x 1-band ⑦	
435	2-bands+1-band		L	2-bands+1-band	
450	2-bands+1-band		L	2-bands+1-band	
465	2 x 2-bands ⑧		L	2-bands+1-band	
480	2 x 2-bands ⑧		L	2-bands+1-band	

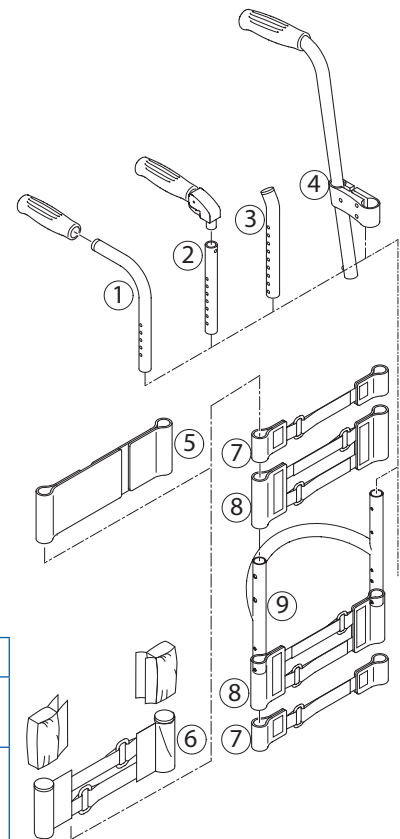

A 1-band strap ⑦ is placed beneath the stabilizing bar if there is a clothes-guard, and a 2-bands strap ⑧ if there is a mudguard.



Backrest height (RH)

The height of the backrest can be adjusted by moving the backrest tube.

Adjusting the backrest height

Readjusting the push handle/telescopic tube

Difficulty: ●○○

Tools: ● 3 8

- Remove the backrest padding.
- Remove the screw connection ① and adjust the desired height of the push handle or the telescopic tube. Insert the screw connection ① again and tighten the nut.
- Carry out the same setting on both sides.
- Refit the backrest padding.

 If the desired height cannot be achieved, you must use a different telescopic tube or push handle.

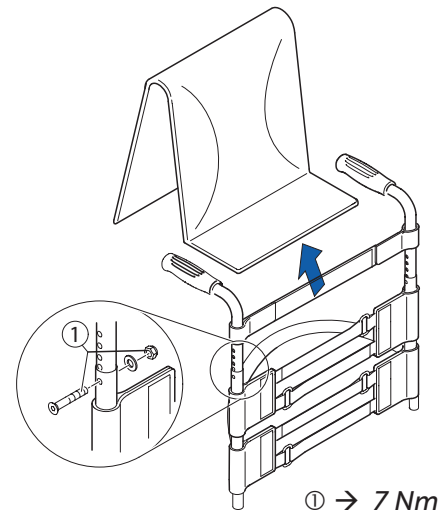

Securing/adjusting the release cord

Difficulty: ●○○



WARNING!

Risk of injury to the user during use as a result of the backrest folding over unintentionally.

If the release cord is too taut, the locking mechanism ② can open unintentionally.

→ Make sure that the release cord is not too taut.

- Knot the release cord ①, left and right, to the wire rings ③ such that it is free from tension, but still ensuring that there is only minimal slack (< 5 mm).

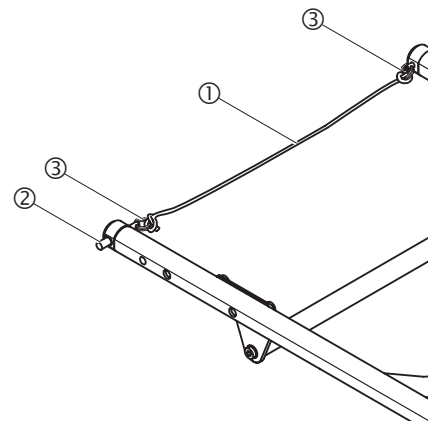



Replacing the backrest tube

Difficulty: ●○○

Tools: ● 3,4 ⬡ 8, 10

- 1** Remove the backrest padding.
- Slide the backrest bands upwards or downwards to gain access to the screws ①. Remove the screws and nuts on both sides.
- Remove the push handles or the telescopic tubes and remove the upper Velcro® bands.
- Remove the screws ② on the backrest joint.
- 2** Remove the lower Velcro® bands and the sleeve ④ with the adjustment screw ⑤ from the backrest tube ③ and fit both to the new backrest tube.
- Fit the backrest tube to the backrest joint with the screws ②. Here, first fit the lower screw followed by the upper screw.
- Fit the upper Velcro® bands and the push handles or the telescopic tubes again and fix them with screws ① and nuts.
- Carry out the same setting on both sides.
- Refit the backrest padding.



The excentre plates must be adjusted identically on both sides of the wheelchair, → Adjusting the backrest angle.

Check:

Check the settings of the adjustment screws ⑤ on both sides. The screw head must only lightly touch the seat module when the backrest is in the upright position. If necessary, readjust the length by releasing the counter nut and tightening or loosening the adjustment screw. Then retighten the counter nut ⑥.



Incorrectly adjusted adjustment screws result in damage to the backrest joint's mechanism, → Adjusting the backrest joint.

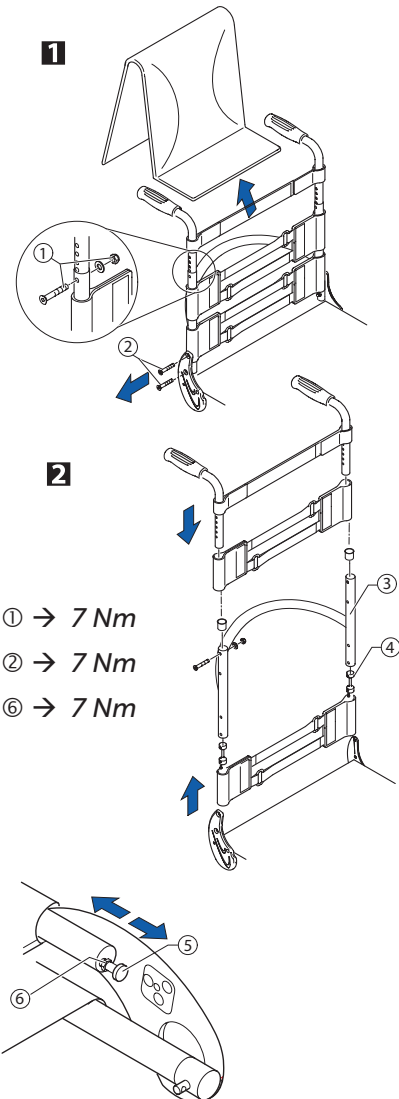



Replacing the handle

An adhesive (e.g. hair spray) is used in these instructions. When applied to the handle, this substance works as a lubricant and as an adhesive once dry.



After drying, the adhesive used must be able to resist a pull-off force of 750 N. If in doubt, contact Küschall® AG.

Difficulty: ●●○

- Remove the old handle.
- Remove any residue (residual adhesive, grease, dust) from the push handle tube.
- Apply a thin layer of hair spray all over the surface of the push handle tube onto which the handle is to be slid.
- Apply a thin layer of hair spray to the inside of the handle.
- Slide the new handle onto the push handle tube.
- Move the handle into the correct position (grooves facing upwards).



If a long handle has been fitted and this is to be replaced with a short one, the push handle tube must be shortened by 35 mm. The push handle tube must be replaced when switching from a short to a long handle.

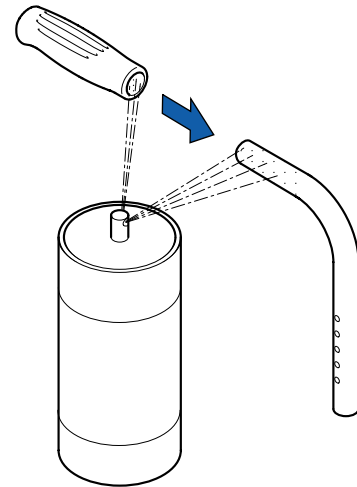

Replacing foldable push handles

Difficulty: ●○○

Tools: Hole punch pliers 6 mm, ● 3, 4

- Remove the old foldable push handle.
- Pull down the backrest cover (F) on the telescopic tube, until its hole (B) is uncovered.
- ! **IMPORTANT!**
Make sure that the threaded insert (E) (part no. 1580450) supplied with the new push handle is used for assembly.
- Place the threaded insert (E) in the telescopic tube.
- Punch a hole through the backrest cover with a distance of 10 mm from the upper edge, using hole punch pliers (see graphic below).
- Slide the new foldable push handle (A) onto the telescopic tube.
- Pull up the backrest cover, until it covers completely the rear hole in the pushhandle.
- Fix the foldable push handle with screw (C) and washer (G).
- Check screws (D) on both sides of the push handle and re-tighten if necessary.
- Carry out the same steps for the other push handle.



Make sure that the folding force is approximately 5 N (0.5 kg).



Fixing screw (C) may only be used once. Alternatively the screw can be cleaned (remove old thread locking adhesive) and reinstalled with new low-strength thread locking adhesive.



The retrofit of foldable push handles requires new tubing.

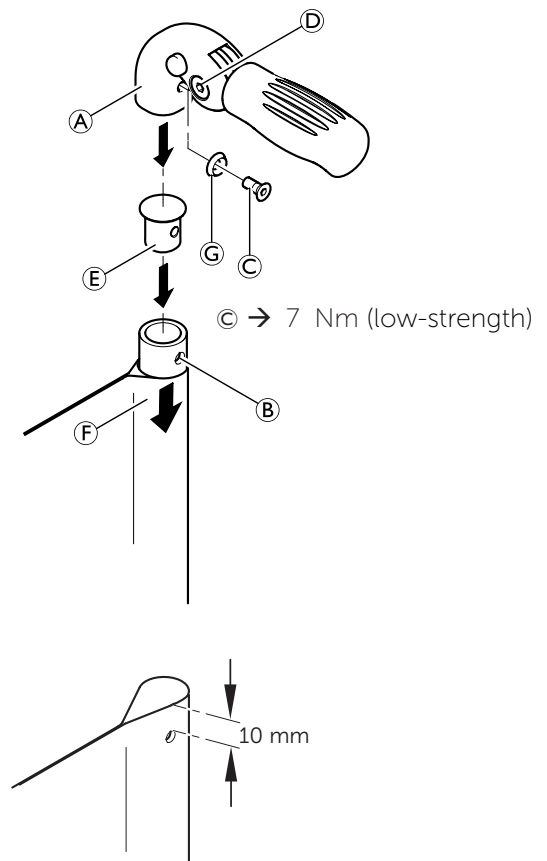



Backrest angle (RW)

The angle of the backrest can be changed by repositioning the excentre plate in the backrest joint plate.

The following angles (measured from the seat) can be set:

74°	78°	82°	86°	90°

Adjusting the backrest angle

Difficulty: ●●○

Tools: ● 3, —C 10

- 1 Fold down the backrest and release the counter nut of the adjustment screw ① and screw it in completely.
- 2 Remove the screw ② on the excentre plate ③. Remove the excentre plate ③ and reinsert it in the desired position.

The excentre plates must be set identically on both sides of the wheelchair.

- Reinsert the screw ② and tighten it.
- Fold the backrest up until the stop bolts ④ engage and unscrew the adjustment screw ① until it touches the frame and the backrest joint no longer moves.
- Tighten the counter nut ⑤.

Adjusting the backrest joint

Difficulty: ●●○

Tools: —C 10

- Put the backrest up and let the pin ① engage.
- Press the backrest forwards to ensure the joint cannot move.
- Unscrew the screw ③ until it touches the spigot ④ of the seat frame.
- Screw the screw back in by between a 1/4 and a 1/2 turn and counter with the counter nut ⑤.
- Correctly adjust the backrest joint on both sides.

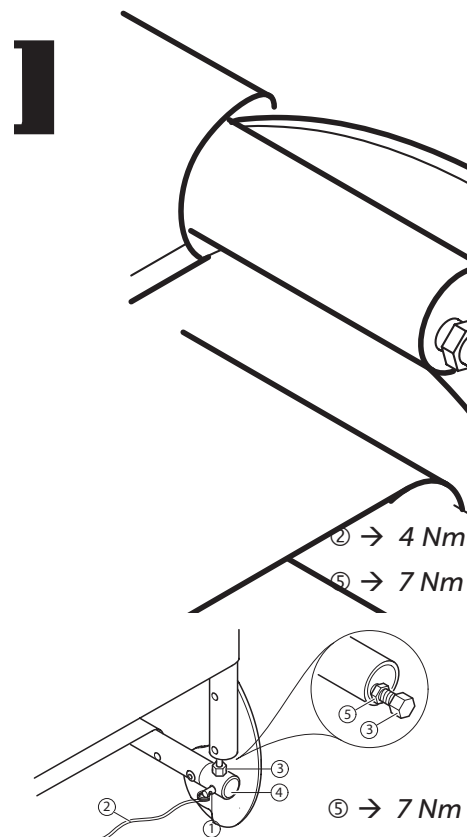

Function check:

Sit in the wheelchair and lean back so that the backrest is strained. Upon pulling the release cord ②, the pin ① must be easily removed on both sides and must fully glide back in upon letting go of the release cord.



FOOTRESTS

The footrest must be selected in accordance with the seat width. A standard footrest and an angle-adjustable footrest are available. Furthermore, there is a choice between a high-mounted footrest and a fold-up footrest.

Lower leg length (UL)

To change the lower leg length, the footrest can be fixed at a higher or lower position. → **Table, Chap. Frame**. The shortest lower leg lengths can be achieved using the high-mounted footrest. → **«Fitting and adjusting high-mounted footrest»**

Replacing footrests

Difficulty: ●○○

Tools: ● 4 8

- Remove the screw connections ① on both sides.
- Remove the footrest and replace it with a new one.
- Tighten the screw connections ① on both sides.
- Carry out the same setting on both sides.

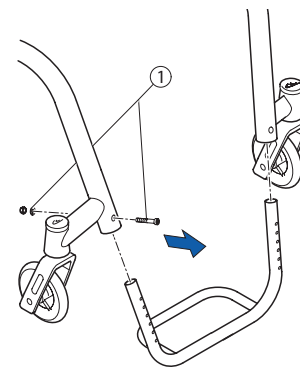

① → 7 Nm / 4 Nm for titanium footrests

Adjusting the footrest height

Difficulty: ●○○

Tools: ● 4 8

The height of the footrest can be adjusted in 10 mm steps.

- Remove the screw connections ① on both sides.
- Slide the footplate to the desired height.
- Tighten the screw connections ① on both sides.
- Carry out the same setting on both sides.

i If the desired lower leg length cannot be achieved, a high-mounted footrest must be used → **«Fitting and adjusting a high-mounted footrest»**

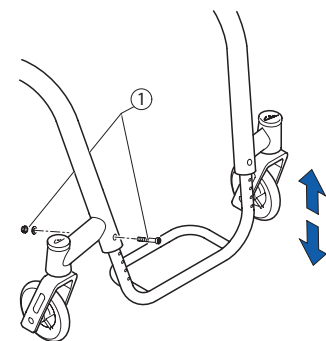

① → 7 Nm / 4 Nm for titanium footrests



Fitting and adjusting high-mounted footrest

Difficulty: ●○○

Tools: ● 4, 5, 8, 10

- 1 Fit the frame bar ④ for the high-mounted footrest to the front frame on both sides using the screw connections ①.
- 2 Fix the clamp set to both sides of the frame ③ using the screw connection ②. Only tighten lightly.
- 3 Slide the high-mounted footplate ⑤ into the clamp set and to the desired height.
- Tighten the screw connections ② on both sides.

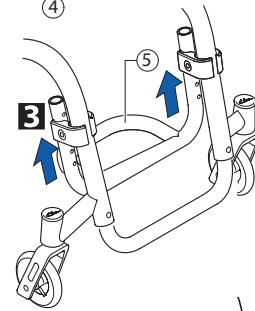
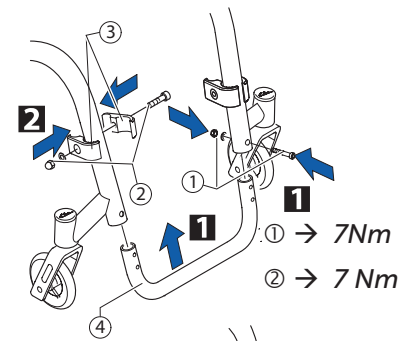

Angle-adjustable footplate, adjusting the angle

Difficulty: ●○○

Tools: ● 4, 10

- To adjust the angle, release the four screw connections ① until the footplate can be moved.
- 1 Check and/or adjust the distance between the left and the right sides by pushing in or pulling out the tubes below the footplate in such a way that the bearings blocks are perpendicular to the ground.
- 2 Tilt the footplate into the desired position and tighten the screw connections ①.



The angle of the footplate must be set so that the user's feet cannot slide off the plate.



Make sure that the footplate has a minimum distance of 20 mm to the floor at its lowest point.

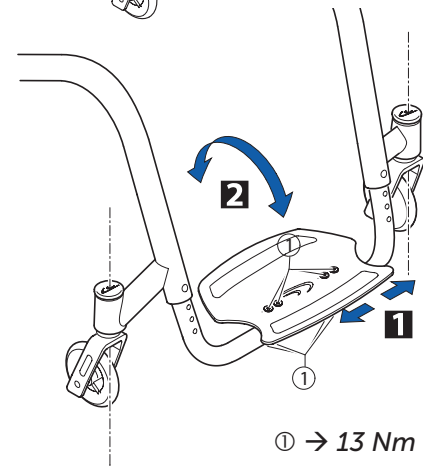



Fit fold-up footrest

Difficulty: ●●○

Tools: ● 4, 5, 8, 10

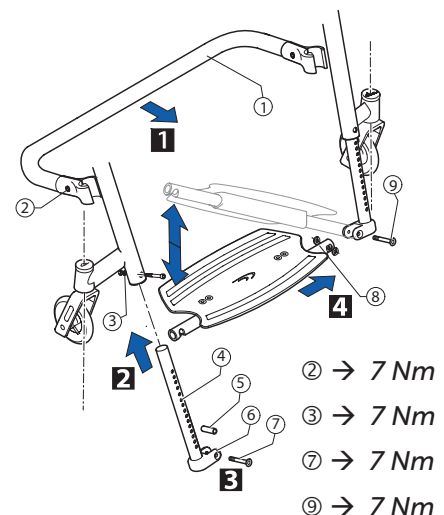
- 1 Fix the reinforcing bar ① to the frame and position it so that the bearings blocks are perpendicular to the ground. Then, firmly tighten the screw connection ②.
- 2 On both sides, slide the telescopic tubes ④ into the frame. On both sides, fix the telescopic tubes at the desired height using the screw connection ③.
- Carry out the same setting on both sides.
- 3 Insert the sleeve ⑤ into the mounting part ⑥ of the right telescopic tube. Fix it using the screw ⑦.
- 4 Place the left tube of the footplate ⑧ into the mounting part on both sides of the left telescopic tube, each with a washer. Fix it using the screw ⑨.
- Insert the right tube of the footplate into the mounting part of the right telescopic tube. Adjust the distance between the left and the right sides by pushing in or pulling out the tubes below the footplate in such a way that the bearings blocks are perpendicular to the ground.
- Tilt the footplate into the desired position and tighten the footplate screws, → Angle-adjustable footplate, adjusting the angle.



 The footrest can also be fitted the other way around (right footrest tube fixed, left tube moving).



SIDE PARTS

Armrest

The clothes-guard fitted as standard can be augmented with an armrest.

Fitting and adjusting an armrest

Difficulty: ●●○

Tools: ● 3, 4, 5 ⬡ 8, 10

- Fold the backrest forwards.
- 1** Remove the backrest spigots① and replace them with the armrest holders on both sides ②.
- 2** Fit the connecting tube on both sides using the screws ③.
- 3** To adjust the height as required, position the sleeve ④ in the tube so that the screw connection ⑤ can be fixed to the appropriate hole in the tube. Place the armrest in the holder.
- Set the desired armrest height on both sides.

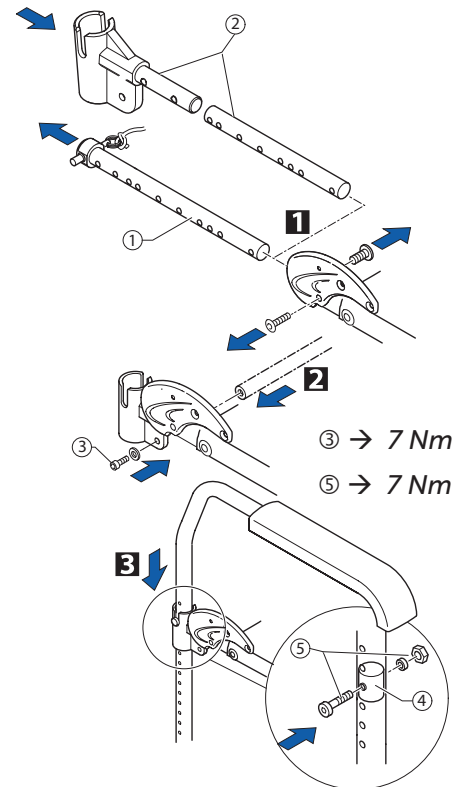

Fitting and adjusting a height-adjustable armrest

Difficulty: ●●○

Tools: ● 4, 5 × 2

- 1** Fit the holder ① and the bracket ② to the seat module on both sides. Tighten the screws ③ only lightly.
- Fit the bar ④ between the two brackets ② using the screws ⑤. Tighten the screws ③.
- 2** To adjust the armrest height, insert the armrest ⑥ into the holder ①.
- Loosen the screws ⑦ for the height adjustment and slide it into the desired position.
- Then retighten the screws ⑦ for the height adjustment.
- By tightening or loosening the screws ⑧, you can adjust how easily the armrest can be pulled out or pushed in.

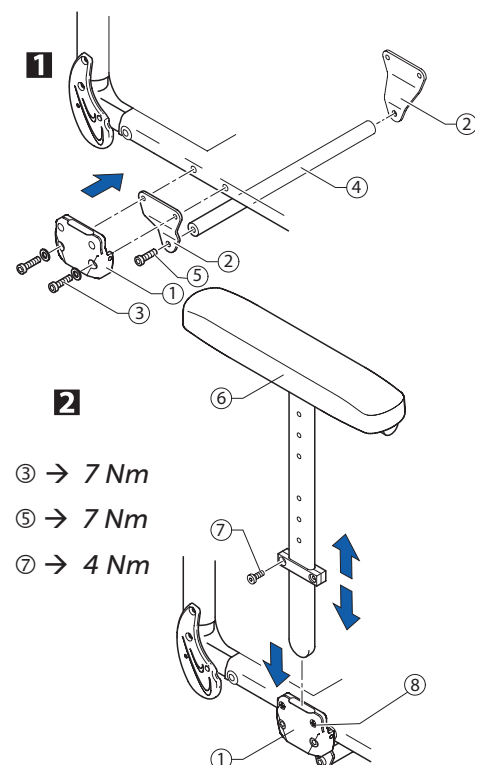



Clothes-guard/mudguard

The clothes-guard fitted as standard can be replaced by a mudguard. Clothes-guard and mudguard are available in plastic or in carbon. For the carbon mudguard there is an additional size (XL) for the two smallest rear seat heights (SHh).

Clothes-guard size			
	Wheel size		
SHh	24"	25"	26"
380	L	—	—
390	L	XL	—
400	L	XL	XL
410	L	L	XL
420	L	L	XL
430	L	L	XL
440	L	L	L
450	L	L	L
460	M	L	L
470	M	M	L
480	M	M	L
490	M	M	L

Mudguard size plastic			
	Wheel size		
SHh	24"	25"	26"
380	L	—	—
390	L	L	—
400	L	L	L
410	L	L	L
420	L	L	L
430	L	L	L
440	M	M	L
450	M	M	L
460	M	M	M
470	M	M	M
480	M	M	M
490	M	M	M

Mudguard size carbon			
	Wheel size		
SHh	24"	25"	26"
380	XL	—	—
390	XL	XL	—
400	L	XL	XL
410	L	XL	XL
420	L	XL	XL
430	L	L	XL
440	M	L	XL
450	M	L	XL
460	M	L	L
470	M	M	L
480	M	M	L
490	M	M	L



Replacing the clothes-guard

The mounting element ① on the backrest must already be fitted.

Difficulty: ●●○

Tools: ● 3, 4

- 1 If present, remove the clothes-guard to be replaced by loosening the screw connection ③.
- Check the correct position of the clothes-guard ② with fitted rear wheel. Here, find the suitable height on the clothes-guard ② for fixing the screw connection ③ to the backrest mount ①.
- 2 If necessary, the holder ④ on the seat module can be replaced. Here, remove the screw ⑤.

 The clothes-guard is correctly positioned if it can be inserted between the seat module and the holder and the upper edge runs above the rear wheel.

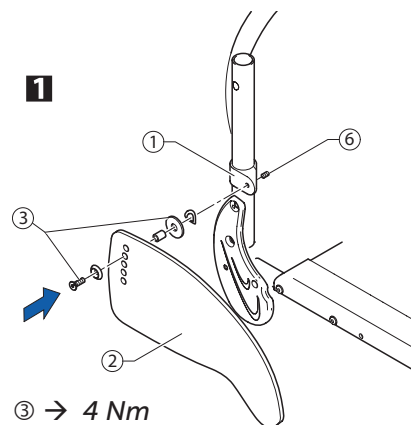

③ → 4 Nm

⑤ → 7 Nm

⑥ → 4 Nm

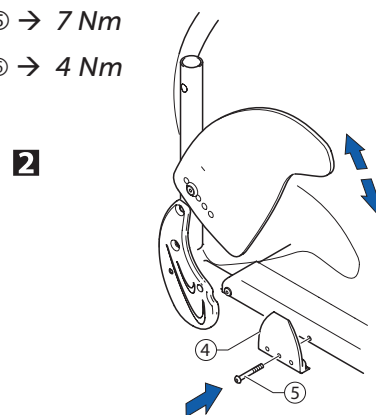

Fitting the mudguard

Difficulty: ●●○

Tools: ● 3, 4, 10 x 2

Remove the clothes-guard and the mounting elements on the backrest and the seat.

- 1 Fit the holder to the seat module using the screw connections ① and then refit the rear wheel.
- 2 Slightly loosen the screws ② on the adjustment plate and slide it along the mudguard carrier until the mudguard is at the right height.
- The position of the mudguard can also be adjusted: Here, loosen the screw connections ③ and ④, position the mudguard as required and tighten the screw connections ③ and ④ again.
- Tighten the screws ② again.
- Carry out the same setting on both sides.
- By tightening or loosening the screws ⑤ you can adjust how easily the armrest can be pulled out or pushed in.

 If the wheelchair is equipped with a suspension, the distance between the mudguard and the wheel must be at least 40 mm.

 The existing axle may not be sufficiently long for the new configuration with mudguard. In this case, a longer axle must be fitted. → Changing the wheel chamber / fitting and adjusting an axle



The distance between the mudguard and the wheel must be either < 8 mm or > 25 mm to prevent fingers from becoming caught between the wheel and the mudguard.

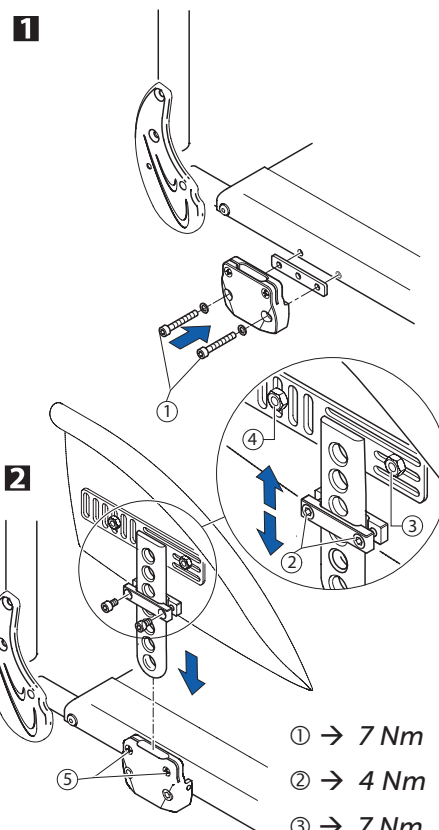

① → 7 Nm

② → 4 Nm

③ → 7 Nm

④ → 7 Nm



FRONT WHEELS

Replacing a front wheel

Difficulty: ●○○

Tools: ● 2x3

- 1 Remove the screw ① with disk on one side. Remove the wheel axle ②.
- 2 Remove the front wheel ③.
- 3 Place the sleeves ④ between the new front wheel ③ and the fork.
- 3 Slide the axle ② through the fork, sleeves ④ and the front wheel ③ and fix the axle using the screw ①. Here, use the new screw supplied with the wheel as this screw comes with a thread-locking device.

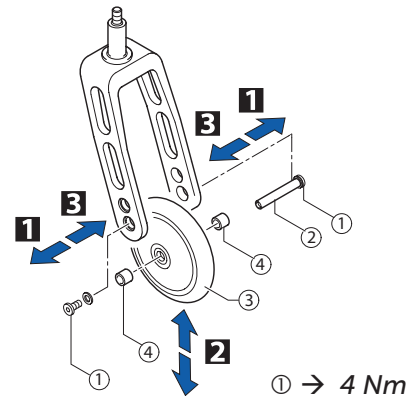

Function check:

The wheel may not wobble, but must rotate easily.

Replacing a front wheel fork

Difficulty: ●●○

Tools: ☰ 10

- Remove the sealing cap ① of the bearings block by inserting two screwdrivers into the grooves and flipping it off.
- Remove the nut ② with the washer ⑤.
- Remove the front wheel fork ③.
- Check the ball bearings ④ and replace them if necessary.
- Insert the new front wheel fork with the washer ⑤ and the nut ② and tighten the nut.
- Carry out the function check (see below).
- Replace the sealing cap ①.

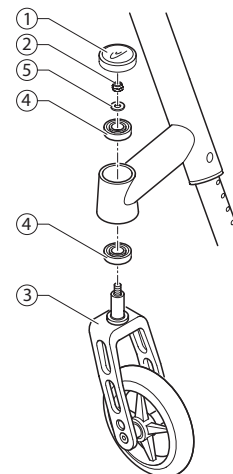

Function check:

Tip the wheelchair backwards by 90° so that it is lying on the backrest and the rear wheels. Turn the fork upwards (position A) and let it tip downwards.

The fork has been correctly adjusted if it easily turns to beyond the bottommost point and remains there (position B).

If the fork turns back to the lower position (position C), it has not been sufficiently tightened. There is a risk that the front wheels will start to wobble at high speeds.

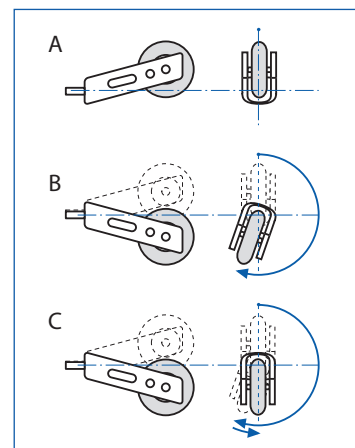



REAR WHEELS

Ensuring the rear wheels are parallel

Difficulty: ●●○

Tools: ● 5

- Loosen the screws ① on both clamp sets. Rotate the axle tube to set the correct position.
- Tighten the screw ① on both sides.



This setting must be carried out on a horizontal surface. The track of the rear wheels is correct if the distance between the rear wheels is the same at the front and the back ($x=y$) – measured at the height of the centre of the axle.

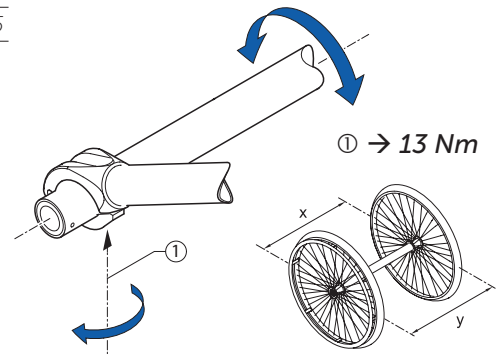

Adjusting the removable axle

Difficulty: ●●○

Tools: — C 11, 19

- Remove the rear wheel.
- Hold the end of the removable axle ② using the straddle spanner.
- Adjust the length L of the removable axle by turning the nut ①. The length is correctly adjusted if the removable axle engages correctly when fixing the wheel and wheel has just minimal clearance.



The wheels must be exchanged (left to right side and vice versa) after adjusting both removable axles. The adjustment must now be checked or carried out again to ensure the wheels can be switched.

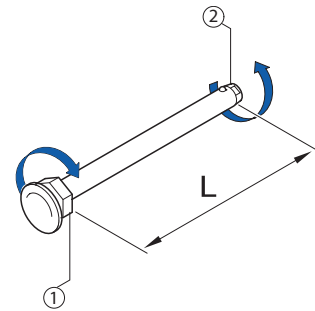

Fitting and adjusting a rear wheel extension

Difficulty: ●●○

Tools: ● 3, 4, 5 ◻ 8

- 1 Remove the screw ① on both sides and remove the axle holder ② with the axle.
- 2 Remove the screws ③ and the screw connections ④ on both sides and remove the axle holder.
- 3 Fit the axle locking ring ⑤ to the desired hole in the rear wheel extension ⑦ using the screws ⑥. Here, do not yet tighten the screws. Slide the two rear wheel extensions onto the axle.



The corresponding locking ring must be used if a Vario-Ax is being fitted.

- 4 Fit the rear wheel extension to both sides of the wheelchair using the screw ①.
- Ensuring the rear wheels are parallel, → **«Ensuring the rear wheels are parallel»**.
 - Tighten the screw ⑧ on the axle locking ring on both sides to fix the axle.
 - Tighten the screws ⑥ on both sides.

① → 13 Nm

⑥ → 7 Nm

⑧ → 7 Nm

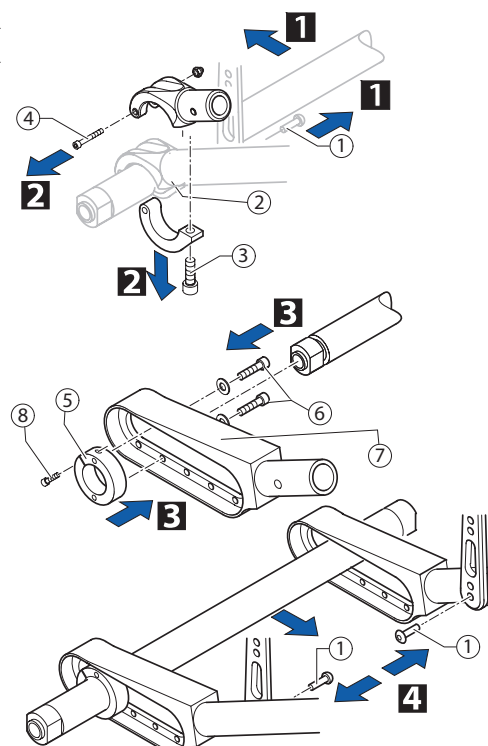



Changing the wheel chamber / Fitting and adjusting an axle

Standard axle

Difficulty: ●●○

Tools: ● 5

A new axle must be used to change the wheel chamber.

- 1 Remove the screws ① on both sides and open up the lower part of the axle holder ②.
 - 2 Replace the axle ③ with a new axle with the desired wheel chamber.
 - 3 Open the lower part of the axle holder ② on both sides and insert the screw ①.
- Ensure the rear wheels are parallel, → Ensuring the rear wheels are parallel.
 - Tighten the screws ① on both sides.

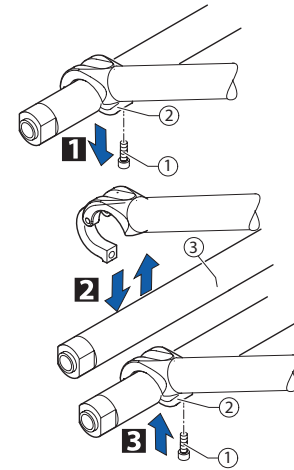

① → 13 Nm

Fitting Vario-Ax

Difficulty: ●●○

Tools: ● 3, 5 ⬡ 8

- 1 Remove the screws ① on both sides and remove the axle holder with the axle.
 - 2 Fit the upper part of the Vario-Ax holder ② on both sides using the screw ①.
 - 3 Insert the Vario-Ax ③ and fit the lower part of the Vario-Ax holder ④ on both sides using the screw connections ⑤ and ⑥.
- Set the desired wheel chamber, → Adjusting the Vario-Ax.
 - Ensure the rear wheels are parallel for wheel chamber 3° or 7°, → Ensuring the rear wheels are parallel.
 - Tighten the screws ⑥ on both sides.

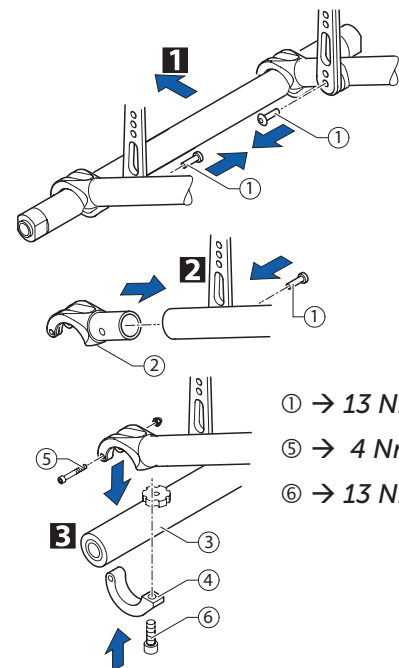

① → 13 Nm

⑤ → 4 Nm

⑥ → 13 Nm

Adjusting the Vario-Ax

Difficulty: ●●○

Tools:

- Loosen the knurled screw ① on the Vario-Ax.
- Pull the rear wheel by the wheel hub ② until the desired wheel chamber is set. Possible settings are 1, 3, 7 and 10 degrees.
- Tighten the knurled screw ① again (not too tight).

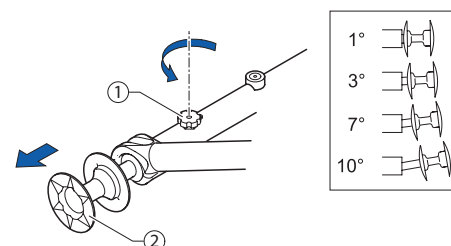



BRAKES

Fitting / adjusting the parking brake

Difficulty: ●●○

Tools: ● 5



Following each positioning, the rear wheel parking brakes (e.g. when changing the wheel chamber) must be readjusted.



The parking brake function is only guaranteed if the tire has the corresponding air pressure.

■ Check that the rear wheels have sufficient air.

1 Loosely fix the clamping piece 2 to the frame with the screw 1.

2 Slide the brake 3 into the correct position and tighten the screw 1.



When the brake is on, the brake shoe 4 must press approx. 4 mm into the tire.



Furthermore, please note that very little force is required for activating and deactivating the brake. If necessary, a brake lever extension can be fitted.

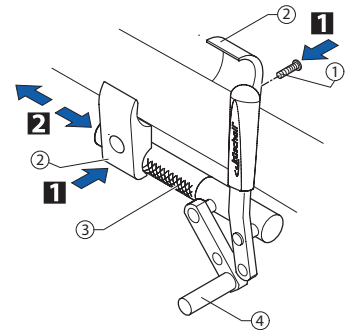

① → 13 Nm / 10 Nm for carbon frame

Visual check

Check that the parking brake is correctly positioned. The brake is correctly adjusted if the brake shoe does not press more than 4 mm into the tire when the brake is on.

Function check

Place the loaded wheelchair on a ramp with a 7° slope with the parking brake on. The wheelchair must not move. Carry out this check with the wheelchair both facing down the ramp and facing up the ramp.



OPTIONS & ACCESSORIES

Antitipper

There are two different sizes of antitipper for both the left and the right sides.

Fit antitipper without rear wheel extension

Difficulty: ●●○

Tools: ● 3, 5 ⬡ 8

- 1 Loosen the screw ① and the screw connection ② and remove the lower part of the axle holder ③.
- 2 Fix the adaptation holder clip ④ with the screw connection ② and the screw ①.
- Check that the rear wheels are parallel, → Chap. Rear wheels; Ensuring the rear wheels are parallel.
- 3 Fix the antitipper to the adaptation holder ④ using the threaded sleeves ⑤ and the screws ⑥. Measure the distance between the antitipper and the ground, → Adjusting the height of the antitipper.

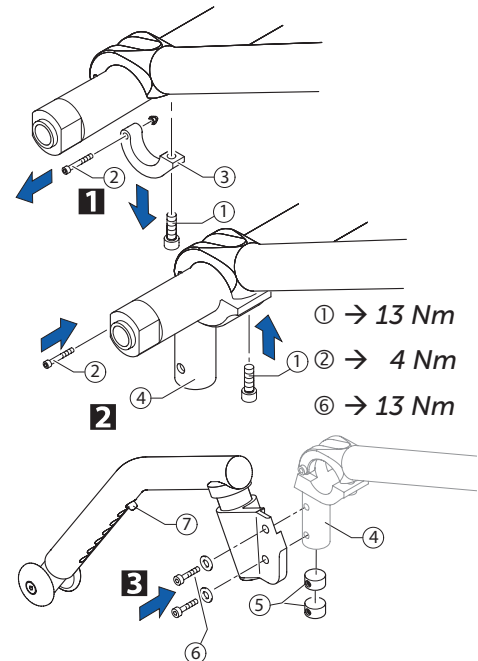

Fit antitipper with rear wheel extension

Difficulty: ●●○

Tools: ● 5 ⬡ 10

The adaptation holder must be fixed to the rear-most position/between the double axles.

- 1 Fix the adaptation holder ① to the rear wheel extension ④ using the spacer sleeves ② and the screw connections ③.

It may be necessary to widen the existing holes to a diameter of 6.1 mm.

- 2 Using the screw connections ⑥ fix the antitipper to the adaptation holder ①. Measure the distance between the antitipper and the ground, → Adjusting the height of the antitipper.

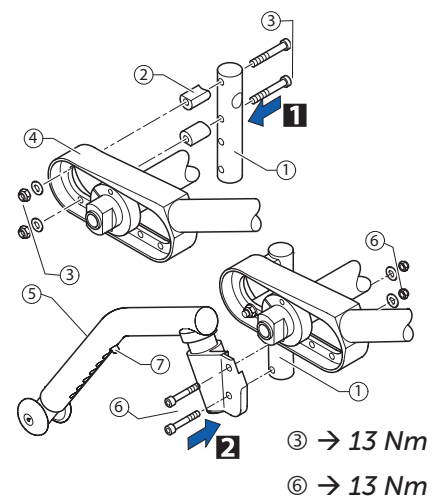

Adjusting the height of the antitipper

- Press the adjustment button ⑦ on the antitipper and pull the antitip tube into the desired position. Let the adjustment button latch into the adjacent hole.

Function check:

The distance between the antitipper and the ground must be 40 - 60 mm. It must be easy to fold up the antitipper.

Tip the wheelchair backwards using the antitipper until the axle is perpendicular to the antitipper's point of contact with the ground. In this position, the distance between the rear wheel and the ground must be at least 50 mm.

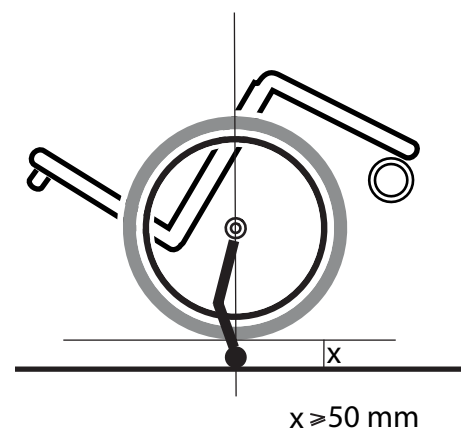



Active antitipper

Fitting and adjusting an active antitipper

Difficulty: ●●●

Tools: ● 3, 5 ○ 8

- 1 Fit the holder ① to the axle tube. Here, only lightly tighten the screws ②.
- 2 Remove the QuickPin ③, slide the active antitipper over the holder and reinsert the QuickPin.
- Turn the antitipper so that it is the desired distance from the ground.
- Carefully remove the antitipper so that the position of the holder ① does not change.
- Tighten the screws ②.
- For the aluminium axle, not for the Vario-Ax: Once the holder ① is correctly positioned, drill into the axle from both sides through the corresponding hole in the holder ① and insert the screw connection ⑤.

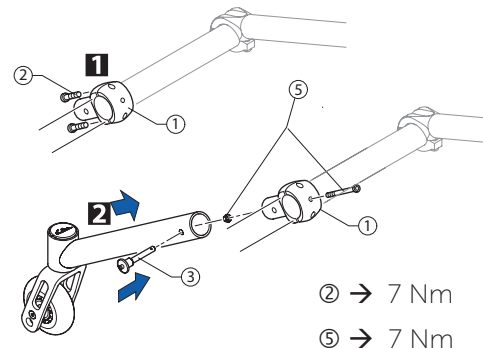

 The active antitipper cannot be fitted to the carbon axle.

Transit wheels

Fitting and adjusting transit wheels

Difficulty: ●●○

Tools: ● 3, 5 ○ 8

- 1 Loosen the screw ① and the screw connection ② and remove the lower part of the axle holder ③.
- 2 Fix the adaptation holder clip ④ with the screw connection ② and the screw ①.
- Check that the rear wheels are parallel, → Chap. Rear wheels; Ensuring the rear wheels are parallel.
- 3 Fix the transit wheel ⑦ using the threaded sleeves ⑤ and the screws ⑥ to the adaptation holder ④.
- Fit a transit wheel on both sides.

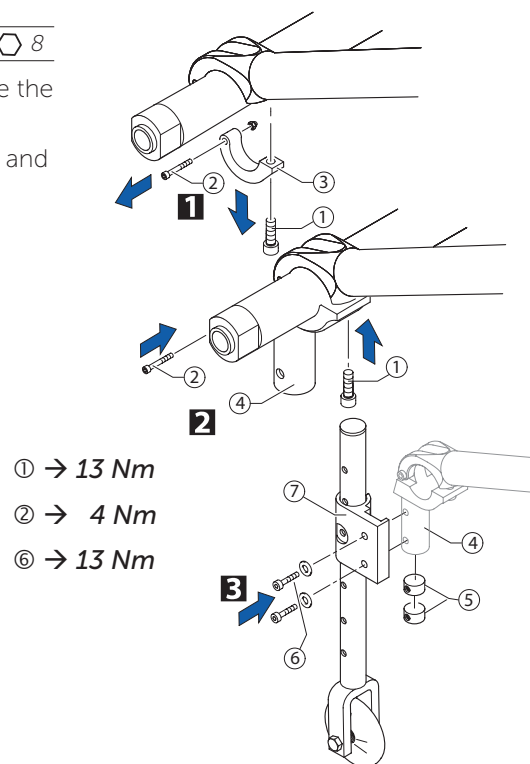



Fitting the pelvic belt

Difficulty: ●○○

Tools: 10 mm

1. Remove cap nut ① and washer ③.
2. Attach the steel strap ④ to the backrest joint screw ② using the supplied, new cap nut ① and washer ③.



Ensure that the webbing of the pelvic belt is not twisted during assembly and the locking mechanism shows towards the front.

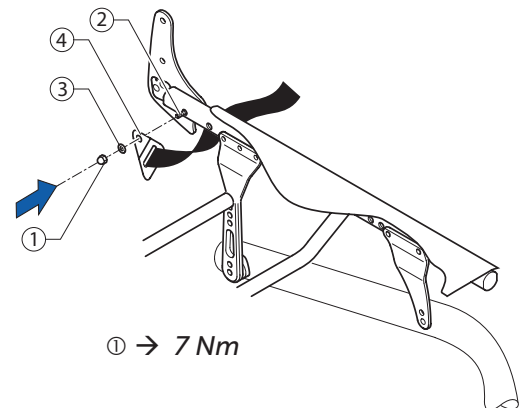

Attaching the snap hook symbols

Front side

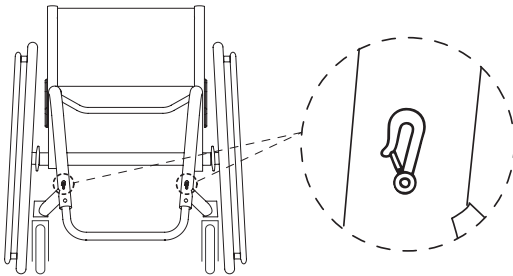

Rear side

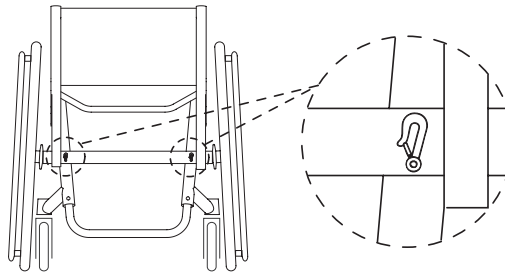



Küschall AG
Benkenstrasse 260
CH-4108 Witterswil
kueschall@invacare.com
www.kuschall.com

Service manual
KÜSCHALL K-SERIES
ENGLISH | 2015-09

küschall[®] distributors

Belgium & Luxemburg: Invacare nv • Autobaan 22 • B-8210 Loppem

Tel: (32) (0)50 83 10 10 • Fax: (32) (0)50 83 10 11 • belgium@invacare.com

Danmark: Invacare A/S • Sdr. Ringvej 37 • DK-2605 Brøndby

Tel: (45) (0)36 90 00 00 • Fax: (45) (0)36 90 00 01 • denmark@invacare.com

Deutschland: Invacare GmbH • Alemannenstraße 10 • D-88316 Isny

Tel: (49) (0)75 62 7 00 0 • Fax: (49) (0)75 62 7 00 66 • kontakt@invacare.com

European Distributor Organisation: Invacare • Kleiststraße 49 • D-32457 Porta Westfalica

Tel: (49) (0)57 31 754 540 • Fax: (49) (0)57 31 754 541 • edo@invacare.com

España: Invacare SA • c/Areny s/n • Polígon Industrial de Celrà • E-17460 Celrà (Girona)

Tel: (34) (0)972 49 32 00 • Fax: (34) (0)972 49 32 20 • contactsp@invacare.com

France: Invacare Poirier SAS • Route de St Roch • F-37230 Fondettes

Tel: (33) (0)2 47 62 64 66 • Fax: (33) (0)2 47 42 12 24 • contactfr@invacare.com

Ireland: Invacare Ireland Ltd • Unit 5 Seatown Business Campus • Seatown Road • Swords • County Dublin – Ireland

Tel: (353) 1 810 7084 • Fax: (353) 1 810 7085 • ireland@invacare.com

Italia: Invacare Mecc San s.r.l. • Via dei Pini 62 • I-36016 Thiene (VI)

Tel: (39) 0445 38 00 59 • Fax: (39) 0445 38 00 34 • italia@invacare.com

Nederland: Invacare BV • Celsiusstraat 46 • NL-6716 BZ Ede

Tel: (31) (0)318 695 757 • Fax: (31) (0)318 695 758 • nederland@invacare.com • cseede@invacare.com

Norge: Invacare AS • Grensesvingen 9 • Postboks 6230 • Etterstad • N-0603 Oslo

Tel: (47) (0)22 57 95 00 • Fax: (47) (0)22 57 95 01 • norway@invacare.com • island@invacare.com

Österreich: Invacare Austria GmbH • Herzog Odilostrasse 101 • A-5310 Mondsee

Tel.: (43) 6232 5535 0 • Fax.: (43) 6232 5535 4 • info@invacare-austria.com

Portugal: Invacare Lda • Rua Estrada Velha • 949 • P-4465-784 Leça do Balio

Tel: (351) (0)225 1059 46/47 • Fax: (351) (0)225 1057 39 • portugal@invacare.com

Sverige & Suomi: Invacare AB • Fagerstagatan 9 • S-163 91 Spånga

Tel: (46) (0)8 761 70 90 • Fax: (46) (0)8 761 81 08 • sweden@invacare.com • finland@invacare.com

Switzerland: Invacare AG • Benkenstrasse 260 • CH-4108 Witterswil

Tel.: (41) (0)61 487 70 80 • Fax.: (41) (0)61 487 70 81 • switzerland@invacare.com

United Kingdom: Invacare Limited • Pencoed Technology Park,

Pencoed, Bridgend CF35 5AQ • Switchboard Tel: (44) (0)1656 776 200, Fax: (44) (0)1656 776 201 •

Customer services Tel: (44) (0) 1656 776 222 • Fax: (44) (0) 1656 776 220

Australia: Invacare Australia Pty Ltd • ABN 45 074 676 378, PO Box 5002, 1 Lenton Place, North Rocks, NSW 2151, Australia •

Freephone: 1800 069 042, Fax: 02 8839 5353 • E-mail: sales@invacare.com.au • Web: www.invacare.com.au

New Zealand: Invacare New Zealand • PO Box 62-124, 4 Westfield Place, Mt. Wellington, Auckland, New Zealand •

Freephone: 8000 468 222, Freefax: 0800 807 788 • E-mail: sales@invacare.co.nz • Web: www.invacare.co.nz